



YSI 550

Handheld Dissolved Oxygen and Temperature System

Operations Manual



CONTENTS

SECTION 1 GENERAL DESCRIPTION	3
1.1 KEYPAD LAYOUT	3
SECTION 2 PREPARING THE YSI 550.....	4
2.1 UNPACKING	4
2.2 WARRANTY CARD	4
2.3 BATTERIES.....	4
2.4 TURNING THE INSTRUMENT ON	5
2.5 CHANGING THE TEMPERATURE UNITS	5
2.6 CALIBRATION/STORAGE CHAMBER.....	5
2.7 HAND STRAP.....	6
2.8 THE INSTRUMENT CASE.....	6
SECTION 3 PREPARING THE PROBE.....	7
3.1 DESCRIPTION	7
3.2 CHOOSING THE RIGHT MEMBRANE	7
3.3 PROBE PREPARATION	7
3.4 MEMBRANE CAP INSTALLATION	7
3.5 PROBE OPERATION AND PRECAUTIONS	8
3.6 PROBE MAINTENANCE	9
3.7 HOW TO REPLACE THE DO PROBE TIP.....	10
SECTION 4 CALIBRATION	12
4.1 BEFORE YOU CALIBRATE.....	12
4.2 THE CALIBRATION PROCESS	12
SECTION 5 PRINCIPLES OF OPERATION.....	15
SECTION 6 TROUBLESHOOTING	17
SECTION 7 WARRANTY AND REPAIR.....	19
APPENDIX A SPECIFICATIONS.....	24
APPENDIX B REQUIRED NOTICE.....	25
APPENDIX C ACCESSORIES/REPLACEMENT PARTS.....	26
APPENDIX D SOLUBILITY TABLE.....	27
APPENDIX E CONVERSION CHART.....	29

SECTION 1 GENERAL DESCRIPTION

The YSI 550 Handheld Dissolved Oxygen Instrument is a rugged, micro-processor based, digital instrument with a field-replaceable YSI dissolved oxygen probe. The YSI 550 DO Instrument is impact-resistant and waterproof.

The YSI 550 DO Instrument is designed for field use and is available with cable lengths of 12 or 25 feet. The body of the probe has been manufactured with stainless steel to add rugged durability and sinking weight. The large Liquid Crystal Display (LCD) is easy to read and is equipped with a back-light for use in dark or poorly lighted areas.

The YSI 550 DO Instrument's micro-processor allows the system to be easily calibrated with the press of a few keys. Additionally, the micro-processor performs a self-diagnostic routine each time the instrument is turned on. The self-diagnostic routine provides you with useful information about the function of the instrument circuitry and the quality of the readings you obtain. For a list of these diagnostic features, see **Section 6, Troubleshooting**.

The system displays temperature in either °C or °F by pressing the **MODE** key and the down arrow at the same time. The instrument also displays dissolved oxygen in either mg/L (milligrams per liter) or % air saturation. The system requires only a single calibration regardless of which dissolved oxygen display you use, however, it will calibrate in mg/L or % saturation. You can switch back and forth from % air saturation to mg/L with a single push of the **MODE** key.

A detachable calibration chamber is mounted to the back of the instrument. A small sponge in the chamber can be moistened to provide a water saturated air environment which is ideal for air calibration. This chamber is also designed for transporting and storing the probe. When the probe is stored in the chamber, the moist environment will prolong effective membrane performance and probe life.

The YSI 550 DO Instrument is powered by 4 C-size alkaline batteries. A new set of alkaline batteries will provide approximately 2000 hours of continuous operation. When batteries need to be replaced, the LCD will display a "**LO BAT**" message. When the LO bat message appears, the instrument will have approximately 50 hours of life left, depending on how much the back light is used. If the backlight is used often, the batteries will be depleted quicker.

The YSI 550 DO Instrument case is waterproof with an IP-67 rating. The YSI 550 DO Instrument is 100% corrosion proof and can be operated in a wet environment without damage to the instrument.

1.1 KEYPAD LAYOUT

The YSI 550 DO keypad consists of six keys. See Figure 1. There are four function keys, and up and down arrow keys. The top left key that has a green circle and line is the ON/OFF key. The top right key is the backlight. The bottom left is the Mode key, and the bottom right is the Enter key.

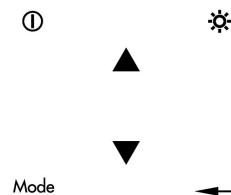

Figure 1

SECTION 2 PREPARING THE YSI 550

2.1 UNPACKING

When you unpack your new YSI 550 DO Handheld Instrument for the first time, check the packing list to make sure you have properly received everything. If there is anything missing or damaged, call the dealer from whom you purchased the YSI 550. If you do not know which authorized dealer sold the system to you, call YSI Customer Service at 800-765-4974 or 937-767-7241.

2.2 WARRANTY CARD

Before you do anything else, please complete the Warranty Card and return it to YSI Incorporated. Your purchase of this quality instrument will then be recorded in YSI's customer database. Once your purchase is recorded, you will receive prompt, efficient service in the event any part of your YSI 550 DO Instrument should ever need repair.

2.3 BATTERIES

There are a few things you must do to prepare your YSI 550 DO instrument for use. First, locate the 4 C-size alkaline batteries that were included with your instrument. See Figure 2.

NOTE: It is very important that the batteries be installed ONLY as illustrated. The instrument will not function if the batteries are installed incorrectly.

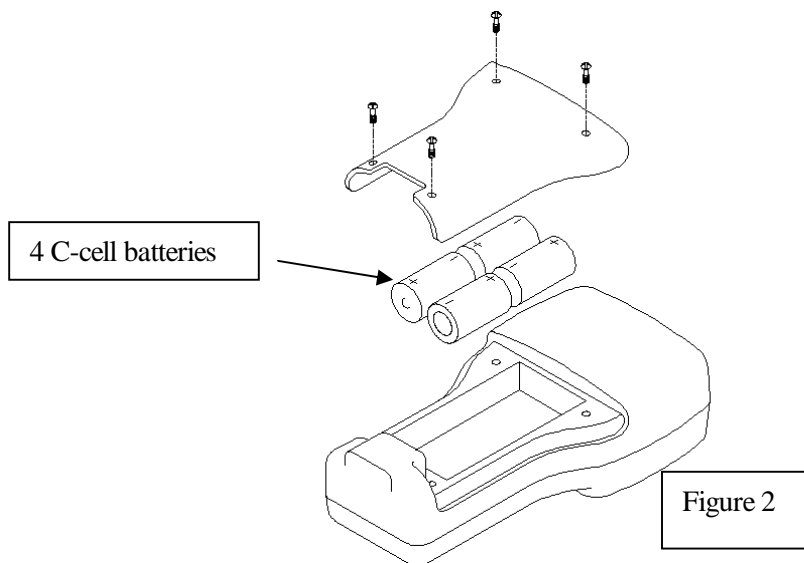

2.4 TURNING THE INSTRUMENT ON

Turn the instrument on by pressing and releasing the **ON/OFF** button on the front of the instrument. The instrument will activate all segments of the display for a few seconds, which will be followed by a self test procedure that will last for several more seconds. During this power on self test sequence, the instrument's microprocessor is verifying that the instrument is working. If the instrument were to detect a problem, a **continuous** error message would be displayed. See **Section 6, Troubleshooting** for error messages. If the instrument does not operate, consult **Section 6, Troubleshooting**.

Because the probe has not yet been prepared, the data displayed on the screen is not accurate.

You may also want to take the instrument into a dark room and, with the instrument turned ON, press the **LIGHT** key. The light key is at the top right of the keypad. The instrument back-light should illuminate the LCD so that the display can be easily read. Pushing the **LIGHT** key again will turn the back light off. The light will power off automatically after two minutes of non-use.

2.5 CHANGING THE TEMPERATURE UNITS

The YSI 550 DO Instrument can display the temperature units in either Fahrenheit or Celsius. To change the units that are displayed, turn the instrument on. Pressing both the down arrow key and the mode key at the same time will switch the units between C or F.

2.6 CALIBRATION/STORAGE CHAMBER

The YSI 550 DO Instrument has a convenient calibration/storage chamber that can be attached to the instrument's back. See Figure 3. The calibration chamber can be used from either side of the instrument, by moving the rubber stopper to either end. This chamber provides an ideal storage area for the probe during transport and extended non-use. If you look into the chamber, you should notice a small round sponge in the bottom. Carefully put 3 to 6 drops of clean water into the sponge. Turn the instrument over and allow any excess water to drain out of the chamber. The wet sponge creates a 100% water saturated air environment for the probe that is ideal for dissolved oxygen calibration.

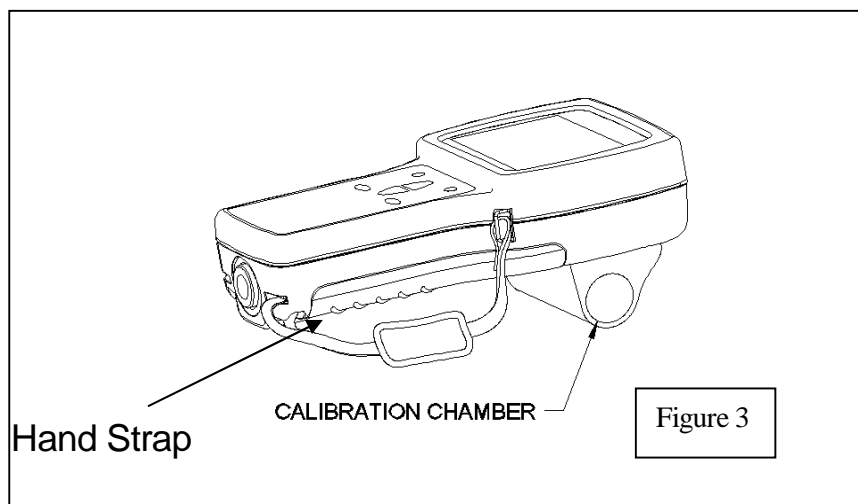

The YSI 550 DO Instrument's storage chamber can be conveniently used from either side of the instrument. To attach the rubber stopper to the calibration chamber, first remove the chamber from the instrument by unscrewing the two screws. After the chamber is free from the instrument, the rubber stopper can be removed from the chamber by pulling the "tail" free of the small hole on the chamber. The stopper can then be re-attached to the storage chamber by threading the "tail" through the small hole on the chamber. The storage chamber can then be re-attached to the instrument using the two screws. See Figure 4.

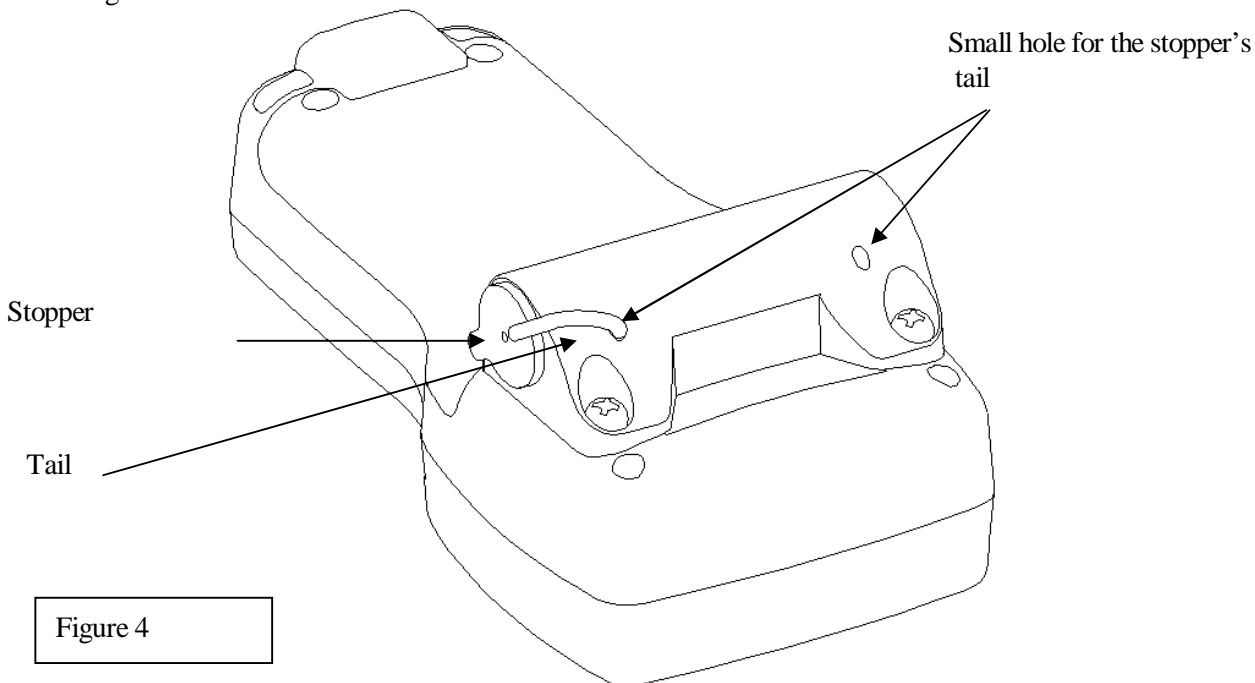

2.7 HAND STRAP

The hand strap is designed to allow comfortable operation of the YSI 550 DO Instrument with minimum effort. If the hand strap is adjusted correctly, it is unlikely that the instrument will be easily dropped or bumped from your hand. The YSI 550 DO Instrument's hand strap can be conveniently used from either side of the instrument.

To switch the hand strap from one side to the other, simply pull the two velcro strips apart. Pull the strap free of the upper and lower hooks, and then feed the strap through the hooks on the other side of the instrument, and adjust the strap length so that your hand is snugly held in place. Press the two velcro strips back together.

2.8 THE INSTRUMENT CASE

The instrument case is sealed at the factory and is not to be opened, except by authorized service technicians.

Caution: Do not attempt to separate the two halves of the instrument case as this may damage the instrument, break the waterproof seal, and will void the manufacturer's warranty.

SECTION 3 PREPARING THE PROBE

3.1 DESCRIPTION

The YSI 550 dissolved oxygen probe is a replaceable, polarographic sensor designed specifically for the YSI 550 Handheld Dissolved Oxygen System. Probe cables are available in lengths of 12 or 25 feet. See Figure 5.

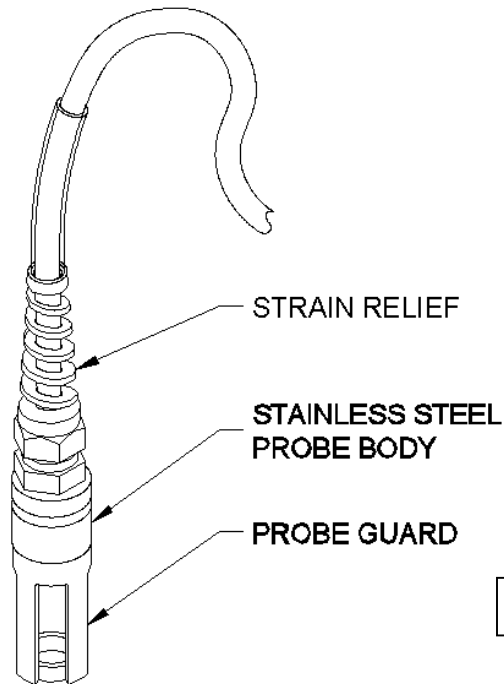

Figure 5

3.2 CHOOSING THE RIGHT MEMBRANE

The YSI 5906 Standard Membrane Kit is supplied with the YSI 550 DO Instrument. This kit contains six cap membranes and a bottle of electrolyte solution. YSI recommends the 5906 membranes for all applications.

3.3 PROBE PREPARATION

The YSI 550 DO probe is shipped dry. **Before using the YSI 550, the protective membrane cap on the probe tip must be removed, the new membrane cap must be filled with electrolyte solution and installed.** Follow the instructions below to replace the membrane cap.

3.4 MEMBRANE CAP INSTALLATION

To install a new membrane cap on your YSI 550 dissolved oxygen probe:

1. Unscrew and remove the probe sensor guard.
2. Unscrew and remove the old membrane cap.

3. Thoroughly rinse the sensor tip with distilled or DI water.
4. Prepare the electrolyte according to the directions on the KCl solution bottle.
5. Hold the membrane cap and fill it at least 1/2 full with the electrolyte solution.
6. Screw the membrane cap onto the probe moderately tight. A small amount of electrolyte should overflow.
7. Screw the probe sensor guard on moderately tight.

CAUTION: Do not touch the membrane surface.

3.5 PROBE OPERATION AND PRECAUTIONS

NOTE: The YSI 550DO Instrument should not be used in a purpose other than that specified by YSI Incorporated. See **Section 7, Warranty and Repair** for details.

1. It is important to recognize that oxygen dissolved in the sample is consumed during probe operation. It is therefore essential that the sample be continuously stirred at the sensor tip. If stagnation occurs, your readings will be artificially low. Stirring may be accomplished by mechanically moving the sample around the probe tip, or by rapidly moving the probe through the sample. The rate of stirring should be at least 1 foot per second.
2. Membrane life depends on usage. Membranes will last a long time if installed properly and treated with care. Erratic readings are a result of loose, wrinkled, damaged, or fouled membranes, or from large (more than 1/8" diameter) bubbles in the electrolyte reservoir. If erratic readings or evidence of membrane damage occurs, you should replace the membrane and the electrolyte solution. The average replacement interval is two to four weeks.
3. If the membrane is coated with oxygen consuming (e.g. bacteria) or oxygen producing organisms (e.g. algae), erroneous readings may occur.
4. Chlorine, sulfur dioxide, nitric oxide, and nitrous oxide can affect readings by behaving like oxygen at the probe. If you suspect erroneous readings, it may be necessary to determine if these gases are the cause.
5. Avoid any environment that contains substances that may attack the probe materials. Some of these substances are concentrated acids, caustics, and strong solvents. The probe materials that come in contact with the sample include FEP Teflon, acrylic plastic, EPR rubber, stainless steel, epoxy, polyetherimide and the PVC cable covering.
6. For correct probe operation, the gold cathode must always be bright. If it is tarnished (which can result from contact with certain gases), or plated with silver (which can result from extended use with a loose or wrinkled membrane), the gold surface must be restored. To restore the cathode, you may either return the instrument to the factory or clean it using the sanding disk in the YSI 5238 Probe Reconditioning Kit. Never use chemicals or abrasives not supplied with this kit.
7. It is also possible for the silver anode, which is the entire silver body of the probe, to become contaminated, which will prevent successful calibration. To clean the anode, follow the Anode

cleaning instructions in the following section. Next, rinse the sensor tip and Electrolyte reservoir with deionized water, add new Electrolyte solution, and install a new membrane and O-ring. Turn the instrument on and allow the system to stabilize for at least 30 minutes. If, after several hours, you are still unable to calibrate, return the YSI 550 DO Instrument to a YSI authorized service center for service, See **Section 7, Warranty and Repair** for more information.

8. To keep the electrolyte from drying out, store the probe in the calibration/storage chamber with the wet sponge.

3.6 PROBE MAINTENANCE

ELECTRODE CLEANING

It is always a good practice to keep the probe in good operating condition.

SILVER ANODE

After extended use, a thick layer of AgCl builds up on the silver anode reducing the sensitivity of the sensor. The anode must be cleaned to remove this layer and restore proper performance. The cleaning can be chemical or mechanical:

- **Chemical cleaning:** Remove the membrane cap and soak the entire anode section in a 14% ammonium hydroxide solution for 2 to 3 minutes, followed by a thorough rinsing with distilled or deionized water. The anode should then be thoroughly wiped with a wet paper towel to remove the residual layer from the anode.
- **Mechanical cleaning:** Sand off the dark layer from the silver anode with 400 grit wet/dry sandpaper. Wrap the wet sandpaper around the anode and twist the probe. Rinse the anode with clean water after sanding, followed by wiping thoroughly with a wet paper towel.

GOLD CATHODE

For correct probe operation, the gold cathode must be textured properly. It can become tarnished or plated with silver after extended use. The gold cathode can be cleaned by using the adhesive backed sanding disc and tool provided in the YSI 5238 Probe Reconditioning Kit.

Using the sanding paper provided in the YSI 5238 Probe Reconditioning Kit, wet sand the gold with a twisting motion about 3 times or until all silver deposits are removed and the gold appears to have a matte finish. If the cathode remains tarnished, return the probe for service. Wipe the gold cathode thoroughly with a wet paper towel before putting on a new membrane cap.

3.7 HOW TO REPLACE THE DO PROBE TIP

The YSI 559 Replaceable DO Module Kit includes:

Quantity	Item
1	Instruction Sheet
1	5906 Membrane Kit
1	Sensor, DO Module
1	Set Screw 4-40x 1/2 long
1	Hex key Wrench, .050"

DO SENSOR REPLACEMENT

Along with the YSI 559 dissolved oxygen module, a YSI 5906 membrane kit, the set screw that holds the sensor in place, YSI supplies a hex key wrench to help install the probe, and an instruction sheet. See Figure 6.

1. Remove probe guard.
2. **IMPORTANT:** Thoroughly dry the sensor so that no water enters the probe port when the sensor is removed.
3. Insert the long end of the hex key wrench into the small hole in the side of the DO sensor module (see figure 1). Turn the wrench counter clockwise and remove the screw. (You do not have to remove the screw all the way to release the sensor.)
4. Pull the DO sensor out of the module. The DO sensor is keyed, or has a flat side, so that it can not be removed improperly.
5. Insert the new probe. Make sure that the inside of the module, and the o-ring of the sensor are clean, with no contaminants, such as grease, dirt, or hair. The DO sensor is keyed, or has a flat side, so that it can not be installed improperly.
- 6a. **IF you did not remove the screw all the way in Step 3:** Use the hex key wrench to tighten the screw in properly, making sure that the screw does not stick out on either side of the DO sensor module.
- 6b. **IF you removed the screw all the way in Step 3:** Insert the set screw into the small hole in the side of the DO sensor module, and turn clockwise to rethread.

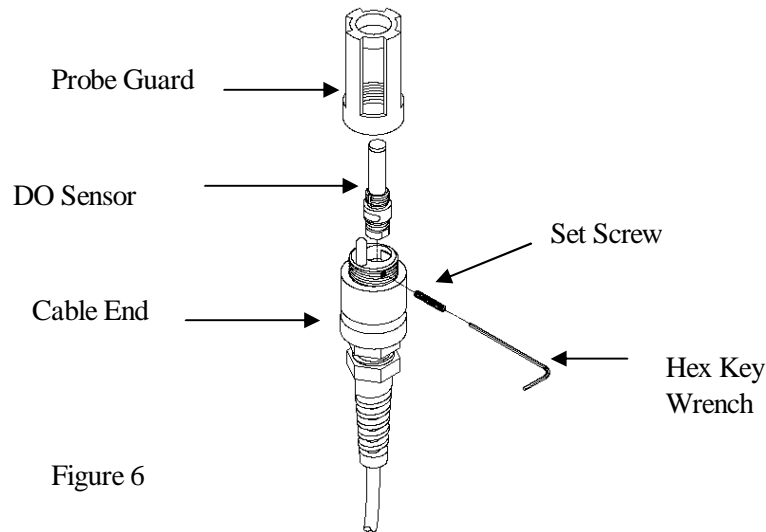

Figure 6

7. The YSI 559 DO module is shipped dry. **Before using the YSI 550 with a new YSI 559 sensor, the protective membrane on the probe tip must be removed, the membrane cap must be filled with electrolyte solution and a new membrane must be installed.** Follow the instructions below to install the electrolyte solution and membrane.

CAUTION: Make sure that you do not cross-thread the screw. Use the hex key wrench to tighten the screw in properly, making sure that the screw does not stick out on either side of the cable end. The probe guard will not thread on properly and damage may result if the screw is allowed to stick out on either side of the cable end.

SECTION 4 CALIBRATION

Dissolved oxygen calibration must be done in an environment with a known oxygen content. Since the amount of oxygen in the atmosphere is known, it makes an excellent environment for calibration (at 100% relative humidity). The calibration/storage chamber contains a sponge to create a 100% water saturated air environment.

4.1 BEFORE YOU CALIBRATE

Before you calibrate the YSI 550 DO Instrument complete the procedures discussed in **Section 2, Preparing the YSI 550** and **Section 3, Preparing the Probe**. You can calibrate the YSI 550 DO Instrument in either mg/L or % saturation. In the section below, you will find instructions on how to calibrate and change between these modes.

Note: While testing to EN-61000-4-6, Conducted RF Immunity, per Table A.1 of EN61326, Electrical Equipment for Measurement, Control and Laboratory Use, the YSI 550 exhibited an ERROR 8 message from 8.6 MHz 22.8 MHz at induced RF voltages of 3-Volts to 1-Volt RMS on the 25-foot probe cable. If you observe this interference please relocate the probe-cable away from heavy industrial equipment power and control cables or communications equipment cables which may be causing the interference.

To accurately calibrate the YSI 550, you will need to know the following information:

- The approximate salinity of the water you will be analyzing. Fresh water has a salinity of approximately zero. Seawater has a salinity of approximately 35 parts per thousand (ppt). If you are uncertain what the salinity of the sample water, use a YSI 30 Salinity-Conductivity-Temperature instrument to determine salinity.
- IF you are going to calibrate in % saturation mode, you need to know the approximate altitude of the region where you are located.

4.2 THE CALIBRATION PROCESS

1. Ensure that the sponge inside the instrument's calibration chamber is moist. Insert the probe into the calibration chamber.
2. Turn the instrument on by pressing the **ON/OFF** button on the front of the instrument. Wait for the dissolved oxygen and temperature readings to stabilize (usually 15 minutes is required after turning the instrument on).
3. To enter the calibration menu, use two fingers to press and release both the **UP ARROW** and **DOWN ARROW** keys at the same time.

TO CALIBRATE IN MG/L:

To switch between mg/L and percent saturation to be displayed as the oxygen readings units, press the Mode key. Either a “mg/L” or “%” will be displayed on the right side of the screen.

4. Make sure that the DO reading (large display) is stable, then press the **ENTER** button. The YSI 550 DO instrument should now display **CAL** in the lower left of the display, the calibration value should be displayed in the lower right of the display and the current DO reading (before calibration) should be on the main display.
5. Make sure that the DO reading (large display) is stable, then press the **ENTER** button. The LCD will prompt you to enter the approximate salinity of the water you are about to analyze. You can enter any number from 0 to 40 parts per thousand (PPT) of salinity. Use the arrow keys to increase or decrease the salinity setting. When the correct salinity appears on the LCD (zero for fresh water), press the **ENTER** key. The instrument will return to normal operation.

Once the calibration process is complete, the only keys that will remain operational are the **MODE** key, the **LIGHT** key and the **ON/OFF** key. You can move back and forth from reading dissolved oxygen in the mg/L mode or the % air saturation mode by pressing the **MODE** key. If you are working in a dark area and have difficulty reading the LCD, press the **LIGHT** key to activate the back-light of the YSI 550. The **ON/OFF** key turns the instrument on or off.

For best results:

- Each time the YSI 550 DO Instrument is turned off, re-calibrate before taking measurements.
- Calibrate at a temperature within $\pm 10^{\circ}\text{C}$ of the sample temperature.

TO CALIBRATE IN % SATURATION:

To switch between mg/L and percent saturation to be displayed as the oxygen readings units, press the Mode key. Either a “mg/L” or “%” will be displayed on the right side of the screen.

4. IF you are calibrating in % saturation mode, the LCD will prompt you to enter the local altitude in hundreds of feet. Use the arrow keys to increase or decrease the altitude.

EXAMPLE: Entering the number 12 here indicates 1200 feet.

6. When the proper altitude appears on the LCD, press the **ENTER** key. The YSI 550 DO Instrument should now display **CAL** in the lower left of the display, the calibration value should be displayed in the lower right of the display and the current DO reading (before calibration) should be on the main display.
7. Make sure that the DO reading (large display) is stable, then press the **ENTER** button. The LCD will prompt you to enter the approximate salinity of the water you are about to analyze. You can enter any number from 0 to 40 parts per thousand (PPT) of salinity. Use the arrow keys to increase

or decrease the salinity setting. When the correct salinity appears on the LCD (zero for fresh water), press the **ENTER** key. The instrument will return to normal operation.

Once the calibration process is complete, the only keys that will remain operational are the **MODE** key, the **LIGHT** key and the **ON/OFF** key. You can move back and forth from reading dissolved oxygen in the mg/L mode or the % air saturation mode by pressing the **MODE** key. If you are working in a dark area and have difficulty reading the LCD, press and hold the **LIGHT** key to activate the back-light of the YSI 550. The **ON/OFF** key turns the instrument on or off.

For best results:

Each time the YSI 550 DO Instrument is turned off, re-calibrate before taking measurements.

- Calibrate at a temperature within $\pm 10^{\circ}\text{C}$ of the sample temperature.

SECTION 5 PRINCIPLES OF OPERATION

The sensor consists of a silver body as the anode and a circular gold cathode embedded in the end. In operation, this end of the sensor is filled with a solution of electrolyte containing a small amount of surfactant to improve wetting action.

A thin semi-permeable membrane, stretched over the sensor, isolates the electrodes from the environment, while allowing gases to enter. When a polarizing voltage is applied to the sensor electrodes oxygen that has passed through the membrane reacts at the cathode causing a current to flow.

The membrane passes oxygen at a rate proportional to the pressure difference across it. Since oxygen is rapidly consumed at the cathode, it can be assumed that the oxygen pressure inside the membrane is zero. Hence, the force causing the oxygen to diffuse through the membrane is proportional to the partial pressure of oxygen outside the membrane. As the oxygen partial pressure varies, so does the oxygen diffusion through the membrane. This causes the probe current to change proportionally.

It is important to recognize that oxygen dissolved in the sample is consumed during the test. It is therefore essential that the sample be continuously stirred at the sensor tip. If stagnation occurs, your readings will be artificially low. Stirring may be accomplished by mechanically moving the sample around the probe tip, or by rapidly moving the probe through the sample. The rate of stirring should be at least 1 foot per second.

DISCUSSION OF MEASUREMENT ERRORS

There are three basic types of dissolved oxygen errors. Type 1 errors are related to limitations of instrument design and tolerances of instrument components. These are primarily the instrument linearity and the resistor tolerances. Type 2 errors are due to basic probe accuracy tolerances, mainly background signal, probe linearity, and variations in membrane temperature coefficient. Type 3 errors are related to the operator's ability to determine the conditions at the time of calibration. If calibration is performed against more accurately known conditions, type 3 errors are appropriately reduced.

TYPE 1 ERRORS

- Instrument linearity error: $\pm 1\%$ of full scale reading, or ± 0.15 mg/L
- Component and circuitry error: ± 0.05 mg/L

TYPE 2 ERRORS

- DO errors caused by temperature compensation for measurements at $\pm 10^\circ\text{C}$ from calibration temperature: $\pm 1\%$ (0.08 mg/L at 25°C)
- DO errors caused by temperature measurement errors: A maximum $\pm 0.2^\circ\text{C}$ temperature error is equal to $\pm 0.5\%$ (0.04mg/L at 25°C).

TYPE 3 ERRORS

- Altitude

- **Operator Error:** A 1000 feet error in altitude (when calibrating) is equal to an error of approximately 3.6% at the 10 mg/L level.
- **Instrument Error:** The maximum DO error caused by calibrating to altitude in increments of 100 feet: $\pm 0.18\%$ (< 0.015 mg/L at 25°C)
- **Humidity:** Errors occur if calibration is performed at less than 100% humidity.

The worst possible case would be calibration at 0% humidity. The error varies with the calibration temperature as follows:

Temperature	Calibration Error at 0% humidity
0°C	0.09 mg/L
10°C	0.14 mg/L
20°C	0.21 mg/L
30°C	0.33 mg/L
40°C	0.50 mg/L

APPROXIMATING THE ERROR

It is unlikely that the actual error in any measurement will be the maximum possible error. A better error approximation is obtained using a root mean squared (r.m.s.) calculation:

$$\text{r.m.s. error} = \pm [1a^2 + 1b^2 + 2a^2 + 2b^2 + 3a^2 + 3b^2]^{1/2} \text{ mg/L}$$

NOTE: This sample calculation is for a near extreme set of conditions.

SECTION 6 TROUBLESHOOTING

NOTE: An error displayed briefly during the first few seconds after turning the instrument on does NOT indicate a problem.

SYMPTOM	POSSIBLE CAUSE	ACTION (Section)
1. Instrument will not turn on	A. Low battery voltage B. Batteries installed incorrectly C. Instrument requires service	A. Replace batteries (2.3) B. Check battery polarity. (2.3) C. Return system for service (7)
2. Instrument will not calibrate	A. Membrane is fouled or damaged B. Probe anode is fouled or dark C. Probe cathode is tarnished D. System requires service	A. Replace membrane and Electrolyte (3) B. Clean anode (3) C. Clean cathode (3) D. Return system for service (7)
3. Instrument "locks up"	A. Instrument has received a shock B. Batteries are low or damaged C. System requires service	A. Remove batteries, wait 15 seconds for reset, replace batteries. (2.3) B. Replace batteries (2.3) C. Return system for service (7)
4. Instrument readings are inaccurate	A. Cal altitude is incorrect B. Salinity setting is incorrect C. Probe not in 100% water saturated air during Cal procedure D. Membrane fouled or damaged E. Probe anode is fouled or dark F. Probe cathode is tarnished G. System requires service	A. Recalibrate w/correct value (4) B. Moisten sponge and place in Cal chamber w/ probe and Recal (2&4) C. Replace membrane (3.4) D. Clean anode (3) E. Clean cathode (3) F. Return system for service (7)
5. LCD displays "LO BAT" or Main display flashes "OFF"	A. Batteries are low or damaged	A. Replace batteries (2.3)
6. Main display reads "Er 0"	A. Calibration current out of range B. Instrument's self-test detects improper probe voltage during calibration	A. Replace membrane and Electrolyte (3.4) B. Clean anode (3) C. Clean cathode (3) D. Return system for service (7)
7. Main display reads "Er 1"	A. Instrument's self-test detects a variance in RAM B. System requires service	A. Remove batteries, wait 15 seconds for reset, replace batteries. (2.3) B. Return system for service (7)
8. Main display reads "Er 4"	A. Sample O ₂ concentration is more than 20 mg/L or below 0 mg/L B. System requires service	A. Recalibrate using correct altitude and salinity compensation (4). B. Replace membrane and Electrolyte (3.4) C. Clean anode (3) D. Clean cathode (3) E. Return system for service (7)

9. Main display reads "Er 6"	A. Sample O ₂ concentration is over or under range (% mode) B. System requires service	A. Recalibrate using correct altitude and salinity compensation (4). B. Replace membrane and Electrolyte (3.4) C. Clean anode (3) D. Clean cathode (3) E. Return system for service (7)
10. Secondary display reads "Er 8" or Main display reads "Er 7"	A. Sample temperature is more than +50°C (122°F) B. System requires service	A. Reduce the sample temperature B. Recalibrate using correct altitude and salinity compensation (4). C. Return system for service (7)
11. Secondary display reads "Er 9" or Main display reads "Er 7"	A. Sample temperature is more than +50°C (122°F) B. System requires service	A. Reduce the sample temperature B. Recalibrate using correct altitude and salinity compensation (4). C. Return system for service (7)

SECTION 7 WARRANTY AND REPAIR

The YSI 550 DO Instrument is warranted for three years from date of purchase by the end user against defects in materials and workmanship. YSI 550 DO probes and cables are warranted for one year from date of purchase by the end user against defects in material and workmanship. Within the warranty period, YSI will repair or replace, at its sole discretion, free of charge, any product that YSI determines to be covered by this warranty.

To exercise this warranty, write or call your local YSI representative, or contact YSI Customer Service in Yellow Springs, Ohio. Send the product and proof of purchase, transportation prepaid, to the Authorized Service Center selected by YSI. Repair or replacement will be made and the product returned, transportation prepaid. Repaired or replaced products are warranted for the balance of the original warranty period, or at least 90 days from date of repair or replacement.

Limitation of Warranty

This Warranty does not apply to any YSI product damage or failure caused by (i) failure to install, operate or use the product in accordance with YSI's written instructions, (ii) abuse or misuse of the product, (iii) failure to maintain the product in accordance with YSI's written instructions or standard industry procedure, (iv) any improper repairs to the product, (v) use by you of defective or improper components or parts in servicing or repairing the product, or (vi) modification of the product in any way not expressly authorized by YSI.

THIS WARRANTY IS IN LIEU OF ALL OTHER WARRANTIES, EXPRESSED OR IMPLIED, INCLUDING ANY WARRANTY OF MERCHANTABILITY OR FITNESS FOR A PARTICULAR PURPOSE. YSI's LIABILITY UNDER THIS WARRANTY IS LIMITED TO REPAIR OR REPLACEMENT OF THE PRODUCT, AND THIS SHALL BE YOUR SOLE AND EXCLUSIVE REMEDY FOR ANY DEFECTIVE PRODUCT COVERED BY THIS WARRANTY. IN NO EVENT SHALL YSI BE LIABLE FOR ANY SPECIAL, INDIRECT, INCIDENTAL OR CONSEQUENTIAL DAMAGES RESULTING FROM ANY DEFECTIVE PRODUCT COVERED BY THIS WARRANTY.

AUTHORIZED U.S. SERVICE CENTERS

North Region

YSI Incorporated • Repair Center • 1725 Brannum Lane • Yellow Springs, Ohio • 45387 •
Phone: (800) 765-4974 • (937) 767-7241 • E-Mail: info@ysi.com

South Region

C.C. Lynch & Associates • 212 E. 2nd Street • Suite 203 • Pass Christian, Mississippi •
39571 • Phone: (800) 333-2252 • (228) 452-4612 • Fax: (228) 452-2563

West Region

EQUIPCO Sales and Service • 1110 Burnett Avenue, Suite D • Concord, CA • 94520 •
Phone: (800)550-5875 • Fax: (510)674-8655



INTERNATIONAL SERVICE CENTERS

YSI Incorporated • Repair Center • 1725 Brannum Lane • Yellow Springs, Ohio • 45387 •
Phone: (937) 767-7241 • E-Mail: info@ysi.com

YSI Europe • Lynchford House • Lynchford Lane • Farnborough • Hampshire • GU146LT •
Phone: (44-1252) 514711 • Fax: (44-1252) 511855 • Tlx: 858210

YSI Japan • Sakura – Building 6-5-6-13 • Shinjuku, Shinjuku-ku, Tokyo • 160 • Phone: (81-3) 5360-3561 • Fax: (81-3) 5360-3565

SPECIALTY SERVICE CENTERS

Aquaculture

Aquatic Eco Systems, Inc. • 1767 Benbow Court • Apopka, Florida • Phone: (407) 886-3939
• Fax: (407) 886-6787

Aquacenter • 166 Seven Oaks Road • Leland, Mississippi • 38756 • Phone: (601) 378-2861 •
Fax: (601) 378-2862

Wastewater

Q.C. Services • P.O. Box 68 • Harrison, Maine • 04040 • Phone: (207) 583-2980

Q.C. Services • P.O. Box 14831 • Portland, Oregon • 97293 • Phone: (503) 236-2712

North Central Labs • 400 Lyons Road • Birnamwood, Wisconsin • Phone: (800) 648-7836 •
Fax: (715) 449-2454

CLEANING INSTRUCTIONS

NOTE: Before they can be serviced, equipment exposed to biological, radioactive, or toxic materials must be cleaned and disinfected. Biological contamination is presumed for any instrument, probe, or other device that has been used with body fluids or tissues, or with waste water. Radioactive contamination is presumed for any instrument, probe or other device that has been used near any radioactive source.

If an instrument, probe, or other part is returned or presented for service without a Cleaning Certificate, and if in our opinion it represents a potential biological or radioactive hazard, our service personnel reserve the right to withhold service until appropriate cleaning, decontamination, and certification has been completed. We will contact the sender for instructions as to the disposition of the equipment. Disposition costs will be the responsibility of the sender.

When service is required, either at the user's facility or at YSI, the following steps must be taken to insure the safety of our service personnel.

1. In a manner appropriate to each device, decontaminate all exposed surfaces, including any containers. 70% isopropyl alcohol or a solution of 1/4 cup bleach to 1 gallon tap water are suitable for most disinfecting. Instruments used with wastewater may be disinfected with .5% Lysol if this is more convenient to the user.
2. The user shall take normal precautions to prevent radioactive contamination and must use appropriate decontamination procedures should exposure occur.
3. If exposure has occurred, the customer must certify that decontamination has been accomplished and that no radioactivity is detectable by survey equipment.
4. Any product being returned to the YSI Repair Center, should be packed securely to prevent damage.
5. Cleaning must be completed and certified on any product before returning it to YSI.

PACKING INSTRUCTIONS

1. Clean and decontaminate items to insure the safety of the handler.
2. Complete and include the Cleaning Certificate.
3. Place the product in a plastic bag to keep out dirt and packing material.
4. Use a large carton, preferably the original, and surround the product completely with packing material.
5. Insure for the replacement value of the product.

Cleaning Certificate

Organization _____

Department _____

Address _____

City _____ State _____ Zip _____

Country _____

Model No. of Device _____ Lot Number _____

Contaminant (if known) _____

Cleaning Agent(s) used _____

Radioactive Decontamination Certified?

(Answer only if there has been radioactive exposure)

___ Yes ___ No

Cleaning Certified By _____

Name

Date

APPENDIX A SPECIFICATIONS

Medium:	Fresh, sea or polluted water
Dissolved Oxygen Sensor:	Steady-State Polarographic
Dissolved Oxygen Probe:	Field-replaceable module
Accuracy:	± 0.3 mg/L or $\pm 2\%$ of reading, whichever is greater $\pm 2\%$ air saturation or $\pm 2\%$ of reading, whichever is greater $\pm 0.2^\circ\text{C}$
Range:	0-20 mg/L 0-200 % air saturation -5° to $+45^\circ$ C temperature
Resolution:	0.01 mg/L 0.1% air saturation 0.1°C temperature
Temperature Units:	Celsius or Fahrenheit, user selectable
Temperature Specifications:	Accuracy: $\pm 0.3^\circ\text{C}$ Range: -5° to $+45^\circ$ C Resolution: 0.1°C
Altitude Compensation:	Yes
Salinity Compensation:	Yes
Temperature Compensation:	Automatic
Power:	4 alkaline C-cells
Size:	4.7 in. width; 9 in. length (11.9 cm x 22.9 cm)
Weight with Batteries:	2 lb. (0.91 kg)
Battery life:	Over 2000 hours at 25°C

APPENDIX B REQUIRED NOTICE

The Federal Communications Commission defines this product as a computing device and requires the following notice:

This equipment generates and uses radio frequency energy and if not installed and used properly, may cause interference to radio and television reception. There is no guarantee that interference will not occur in a particular installation. If this equipment does cause interference to radio or television reception, which can be determined by turning the equipment off and on, the user is encouraged to try to correct the interference by one or more of the following measures:

- re-orient the receiving antenna
- relocate the YSI Instrument with respect to the receiver
- move the YSI Instrument away from the receiver
- plug the YSI Instrument into a different outlet so that the computer and receiver are on different branch circuits.

If necessary, the user should consult the dealer or an experienced radio/television technician for additional suggestions. The user may find the following booklet, prepared by the Federal Communications Commission, helpful: "How to Identify and Resolve Radio-TV Interference Problems." This booklet is available from the U.S. Government Printing Office, Washington, DC 20402, Stock No. 0004-000-00345-4.

Note: While testing to EN-61000-4-6, Conducted RF Immunity, per Table A.1 of EN61326, Electrical Equipment for Measurement, Control and Laboratory Use, the YSI 550 exhibited an ERROR 8 message from 8.6 MHz 22.8 MHz at induced RF voltages of 3-Volts to 1-Volt RMS on the 25-foot probe cable. If you observe this interference please relocate the probe-cable away from heavy industrial equipment power and control cables or communications equipment cables which may be causing the interference.

APPENDIX C ACCESSORIES/REPLACEMENT PARTS

The following parts and accessories are available from YSI or any YSI Authorized Dealer.

YSI Model Number	Description
559	Replacement DO Module
5906	6 Cap Membranes and Electrolyte Solution
5238	Probe Reconditioning Kit (sanding tool and disks for cathode cleaning)
5060	Carrying Case, Soft-sided
5080	Carrying Case, Hard
5085	Hands-Free Holster
5065	Leather Carrying Case, 550, 556, 650

APPENDIX D SOLUBILITY TABLE

Solubility of Oxygen in mg/L in Water Exposed to Water-Saturated Air at 760 mm Hg Pressure.

Salinity = Measure of quantity of dissolved salts in water.

Chlorinity = Measure of chloride content, by mass, of water.

$$S(\text{‰}) = 1.806550 \times \text{Chlorinity} (\text{‰})$$

This table is provided for your information only. It is **NOT** required when calibrating the YSI 550 DO Instrument in accordance with the instructions outlined in the **Section 4, Calibration**.

Temp °C	Chlorinity: 0 Salinity: 0	5.0 ppt 9.0 ppt	10.0 ppt 18.1 ppt	15.0 ppt 27.1 ppt	20.0 ppt 36.1 ppt	25.0 ppt 45.2 ppt
0.0	14.62	13.73	12.89	12.10	11.36	10.66
1.0	14.22	13.36	12.550	11.78	11.07	10.39
2.0	13.83	13.00	12.22	11.48	10.79	10.14
3.0	13.46	12.66	11.91	11.20	10.53	9.90
4.0	13.11	12.34	11.61	10.92	10.27	9.66
5.0	12.77	12.02	11.32	10.66	10.03	9.44
6.0	12.45	11.73	11.05	10.40	9.80	9.23
7.0	12.14	11.44	10.78	10.16	9.58	9.02
8.0	11.84	11.17	10.53	9.93	9.36	8.83
9.0	11.56	10.91	10.29	9.71	9.16	8.64
10.0	11.29	10.66	10.06	9.49	8.96	8.45
11.0	11.03	10.42	9.84	9.29	8.77	8.28
12.0	10.78	10.18	9.62	9.09	8.59	8.11
13.0	10.54	9.96	9.42	8.90	8.41	7.95
14.0	10.31	9.75	9.22	8.72	8.24	7.79
15.0	10.08	9.54	9.03	8.54	8.08	7.64
16.0	9.87	9.34	8.84	8.37	7.92	7.50
17.0	9.67	9.15	8.67	8.21	7.77	7.36
18.0	9.47	8.97	8.50	8.05	7.62	7.22
19.0	9.28	8.79	8.33	7.90	7.48	7.09

Temp °C	Chlorinity: 0 Salinity: 0	5.0 ppt 9.0 ppt	10.0 ppt 18.1 ppt	15.0 ppt 27.1 ppt	20.0 ppt 36.1 ppt	25.0 ppt 45.2 ppt
20.0	9.09	8.62	8.17	7.75	7.35	6.96
21.0	8.92	8.46	8.02	7.61	7.21	6.84
22.0	8.74	8.30	7.87	7.47	7.09	6.72
23.0	8.58	8.14	7.73	7.34	6.96	6.61
24.0	8.42	7.99	7.59	7.21	6.84	6.50
25.0	8.26	7.85	7.46	7.08	6.72	6.39
26.0	8.11	7.71	7.33	6.96	6.62	6.28
27.0	7.97	7.58	7.20	6.85	6.51	6.18
28.0	7.83	7.44	7.08	6.73	6.40	6.09
29.0	7.69	7.32	6.96	6.62	6.30	5.99
30.0	7.56	7.19	6.85	6.51	6.20	5.90
31.0	7.43	7.07	6.73	6.41	6.10	5.81
32.0	7.31	6.96	6.62	6.31	6.01	5.72
33.0	7.18	6.84	6.52	6.21	5.91	5.63
34.0	7.07	6.73	6.42	6.11	5.82	5.550
35.0	6.95	6.62	6.31	6.02	5.73	5.46
36.0	6.84	3.52	6.22	5.93	5.65	5.38
37.0	6.73	6.42	6.12	5.84	5.56	5.31
38.0	6.62	6.32	6.03	5.75	5.48	5.23
39.0	6.52	6.22	5.98	5.66	5.40	5.15
40.0	6.41	6.12	5.84	5.58	5.32	5.08
41.0	6.31	6.03	5.75	5.49	5.24	5.01
42.0	6.21	5.93	5.67	5.41	5.17	4.93
43.0	6.12	5.84	5.58	5.33	5.09	4.86
44.0	6.02	5.75	5.50	5.25	5.02	4.79
45.0	5.93	5.67	5.41	5.17	4.94	4.72

APPENDIX E CONVERSION CHART

To Convert From	To	Equation
Feet	Meters	Multiply by 0.3048
Meters	Feet	Multiply by 3.2808399
Degrees Celsius	Degrees Fahrenheit	$(^{\circ}\text{C} \times 9/5) + 32$
Degrees Fahrenheit	Degrees Celsius	$(^{\circ}\text{F} - 32) \times 5/9$
Milligrams per liter (mg/L)	Parts per million (ppm)	Multiply by 1

YSI incorporated



1700/1725 Brannum Lane
Yellow Springs, Ohio 45387 USA
(800) 765-4974 (937) 767-7241
FAX: (937) 767-9320
Website: <http://www.yei.com>
E-mail: info@ysi.com

Item #655126
Drawing # A655126
Revision A